



**Bobcat®**

**COMPACT EXCAVATORS**

**E85**



***One Tough Animal®***

# E85 — SPECIFICATIONS

## Weights

Operating weight	8540 kg
Additional weight for steel tracks	112 kg
Additional weight for long dipperstick	60 kg
Ground pressure with rubber tracks	38.20 kPa

## Engine

Make / model	Yanmar / 4TNV98C-VDB8
Fuel	Diesel
Number of cylinders	4
Displacement	3319 cm <sup>3</sup>
Maximum NET power (ISO 9249)	44.3 kW
Maximum NET torque (ISO 9249)	241.0 Nm

## Performance

Digging force, dipperstick (ISO 6015)	43900 N
Digging force, long dipperstick (ISO 6015)	36600 N
Digging force, bucket (ISO 6015)	64700 N
Drawbar pull	64700 N
Travel speed, low range	2.7 km/h
Travel speed, high range	4.7 km/h

## Hydraulic System

Pump type	One engine-driven tandem axial piston pump and one engine-driven gear pump
Piston pump capacity	151.00 L/min
Auxiliary flow	95.00 L/min
System relief pressure for auxiliary circuits	250.00 bar
Auxiliary relief	210.00 bar
Relief pressure for implement circuit	295.00 bar

## Slew System

Boom swing, left	70.0°
Boom swing, right	55.0°
Slew rate	9.5 RPM

## Fluid Capacities

Cooling system	10.00 L
Engine lubrication plus oil filter	10.20 L
Fuel reservoir	110.00 L
Hydraulic system	148.00 L

## Environmental

Noise level LpA(EU Directive 2006/42/EC)	71 dB(A)
Noise level LWA(EU Directive 2000/14/EC)	98 dB(A)
Whole body vibration (ISO 2631-1)	0.32 ms <sup>-2</sup>
Hand-arm vibration (ISO 5349-1)	0.82 ms <sup>-2</sup>

## Standard Features

2300 mm dozer blade	Boom & arm safety valves
450 mm rubber tracks	Harness for rotating beacon
5.7 inch LCD screen	Fully adjustable air conditioning
Engine/hydraulic monitor with shutdown	Overload warning device
Fingertip auxiliary hydraulic control	Sun visor
Control console locks	Left rear view mirror
Hydraulic joystick controls	Electric refueling pump
Two-speed travel	Auto idle
Lockable storage compartment	Auto shift travel
Horn	Auxiliary hydraulics (1st and 2nd circuits)
Work lights	Auxiliary lines on arm with quick couplers
Retractable seat belt	Warranty: 12 months, 2000 hours (whichever occurs first)
Suspension seat with high back	Travel motion alarm
Consoles with forwards/backwards adjustable displacement	

## Working Range

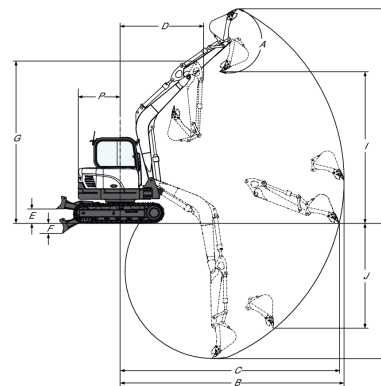

(A)	182.0°	(G)	5007.0 mm
(B)	6915.0 mm	(H)	6630.0 mm
(C)	7430.0 mm	(H*)	6980.0 mm
(C)	6765.0 mm	(I)	4645.0 mm
(C*)	7295.0 mm	(I*)	4995.0 mm
(D)	2550.0 mm	(J)	3245.0 mm
(D*)	2635.0 mm	(J)	3755.0 mm
(E)	437.0 mm	(K)	4175.0 mm
(F)	304.0 mm	(K*)	4725.0 mm

## Dimensions

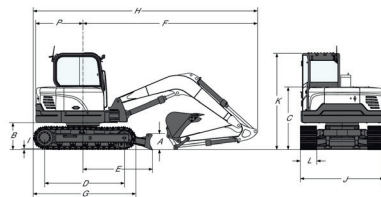

(A)	408.0 mm	(I)	26.0 mm
(B)	735.0 mm	(J)	2300.0 mm
(C)	1715.0 mm	(K)	2640.0 mm
(D)	2200.0 mm	(L)	450.0 mm
(E)	1910.0 mm	(M)	704.0 mm
(F)	4785.0 mm	(N)	837.0 mm
(G)	2825.0 mm	(O)	2550.0 mm
(H)	6165.0 mm	(P)	1300.0 mm
(H*)	6265.0 mm	(Q)	2166.0 mm

## Options

Steel tracks	Long dipperstick
Third auxiliary hydraulic line (Clamshell Piping)	

Certain specification(s) are based on engineering calculations and are not actual measurements. Specification(s) are provided for comparison purposes only and are subject to change without notice. Specification(s) for your individual Bobcat equipment will vary based on normal variations in design, manufacturing, operating conditions, and other factors. Pictures of Bobcat units may show other than standard equipment.



**Bobcat is a Doosan Company.**

Doosan is a global leader in construction equipment, power & water solutions, engines, and engineering proudly serving customers and communities for more than a century. | Bobcat and the Bobcat logo are registered trademarks of Bobcat Company in the United States and various other countries. ©2017 Bobcat Company. All Rights Reserved.



# Bobcat®

[www.bobcat.com](http://www.bobcat.com)